

A

B

C

D

E

F

PRO/E

NOTES:

1. PART TO CONFORM TO FASTEX CLASS "B" WORKMANSHIP STANDARDS.
2. ALL DIMENSIONS ARE IN INCHES.
3. SEE CUSTOMER SERVICE FOR VALID END CODES, BOX QTY, BOX SIZE, ETC.

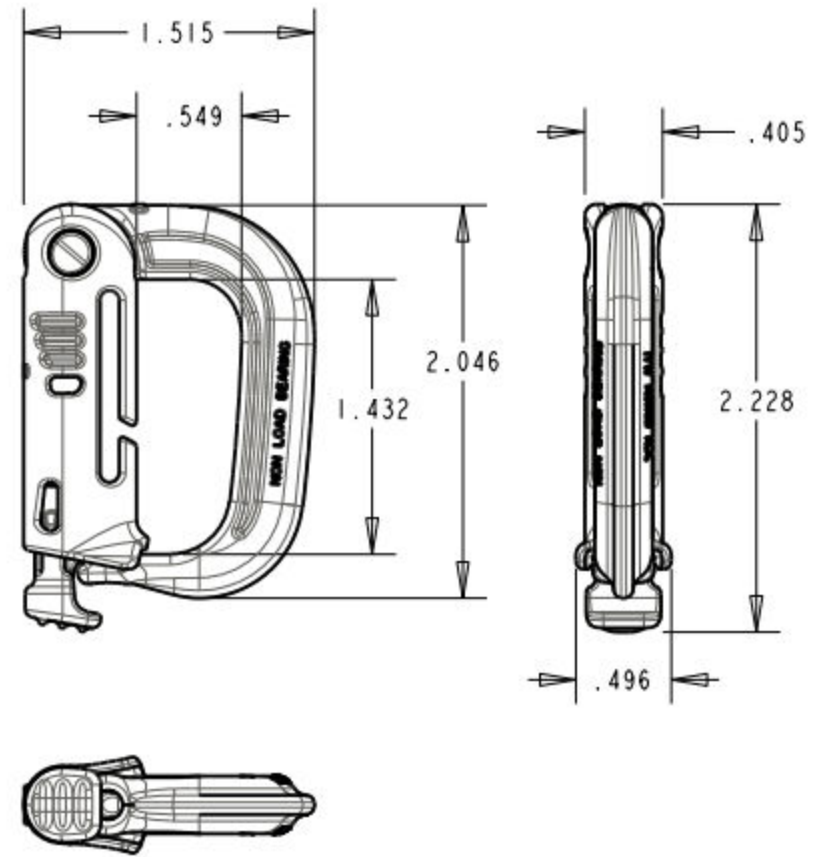

1	6204	RELEASED FOR PROD.	M GRIMM	06-07-05
---	------	--------------------	---------	----------

NO.	ECN#	REVISION	APPROVAL	DATE
DRAWN BY	M. GRIMM	DATE	03/03/2004	
CHK BY	N/A	DATE	N/A	
APP BY	N/A	DATE	N/A	

MATERIAL	SEE NOTES
HARDNESS	SEE NOTES
FINISH	SEE NOTES

TOLERANCE UNLESS OTHERWISE INDICATED
 DECIMAL $\pm .030$ ANGULAR $\pm 1^\circ$
 ENGINEER M. GRIMM SCALE 1:1

This print and any design thereon is the property of FASTEX, Division Illinois Tool Works Inc. This print is to be returned upon request or completion of the work for which it was issued. It is to be used only for the purpose for which it was expressly loaned and is not to be copied in any manner, nor is information taken therefrom to be transmitted, or passed on to others without written permission of Illinois Tool Works Inc.

Available from		THE CLIP.com Device Portability Experts	
NAME		GRIMLOC	
FTA#	PROJ# N01-04-001		
PART#	110-4100	ISSUE	1

ALL CHANGES TO OCCUR ON CAD SYSTEM

SALES DRAWING